

SMA825B-174 T124316101TU

品名: SMA バルクヘッドジャック RG174 RG316 ケーブル (φ2.5mm) 用

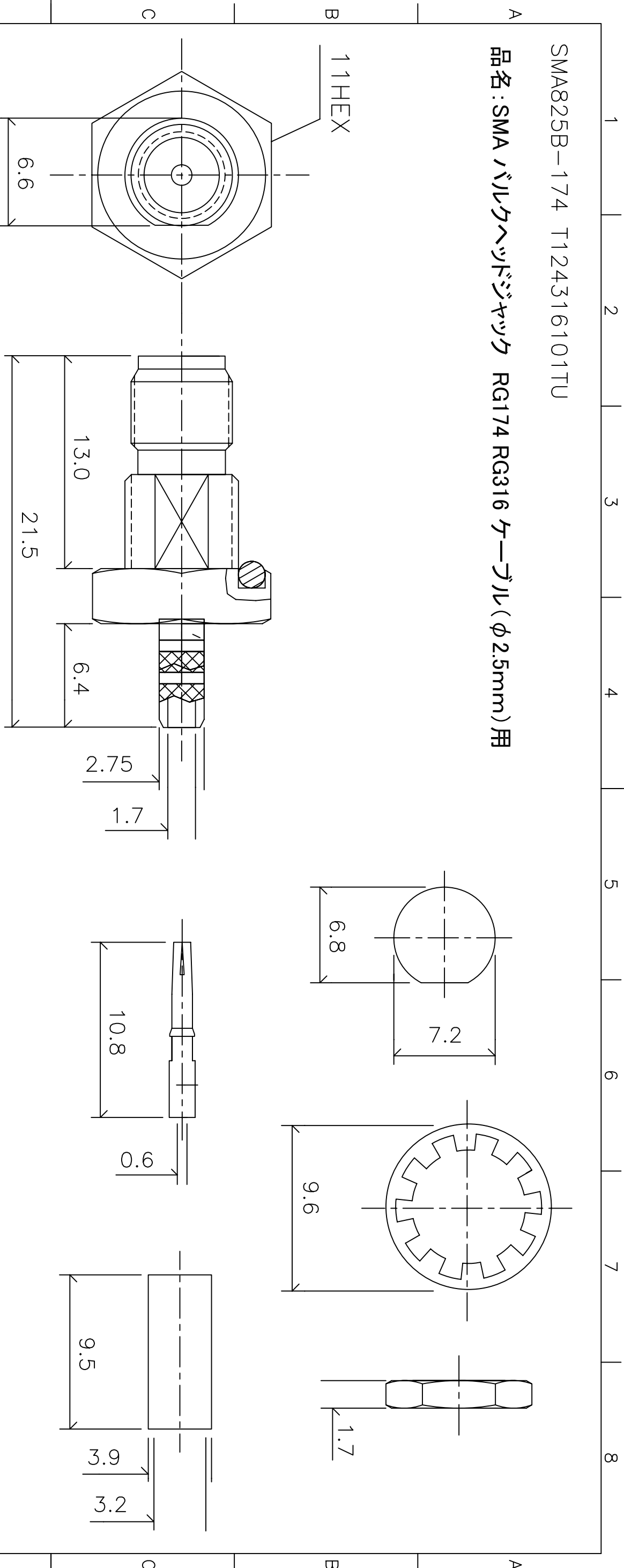

Electrical

Impedance: 50 Ω
 Frequency: DC-12.4GHz
 V.S.W.R: 1.19Max at 2.0GHz
 Insulation Resistance: 5000MΩ Minimum
 Contact Resistance:
 Center Contact: 4mΩ
 Outer Contact: 3mΩ
 Insulator Withstanding Voltage: 750VRMS

Mechanical

- ① Body: Brass Gold Finish 5 μ Inch
 - ② Center contact: BeCu, Finish 30 μ Inch
 - ③ Insulator: Teflon
 - ④ Felleule: Brass Gold finish 5 μ Inch
- Brass Material: Cd < 75ppm, Pb < 40,000ppm
 RoHs Regulation: Comply
 Dulability: 500cycles

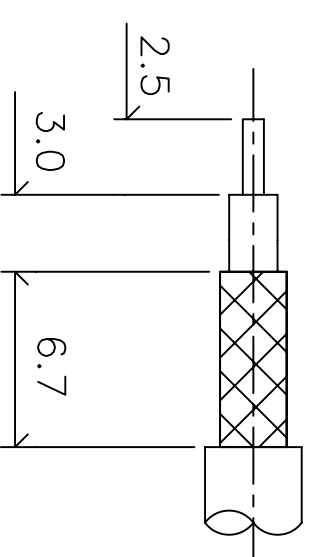

△	- -		
△	- -		
△	- -		
△	- -		
△	- -		

未記入公差		尺度	単位	TAKITEK	
長度公差: ± 0.08	直径公差: ± 0.03		mm	タキテック株式会社	
				製品名	SMA bulkhead Jack for
				部品名	RG174 (φ2.6mm)
				部品名	T124 316 101
				製図	設計
				照査	