

SMA835-58 T124318000TU

品名: SMAジャック バルクヘッド RG58 ケーブル (φ5.0mm)用

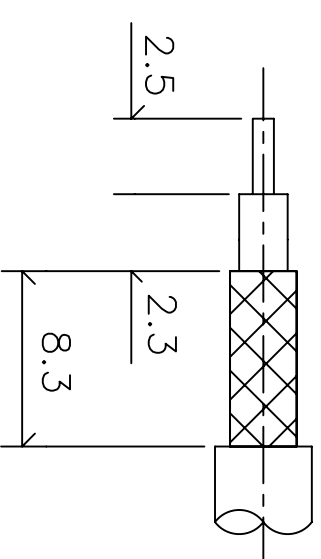
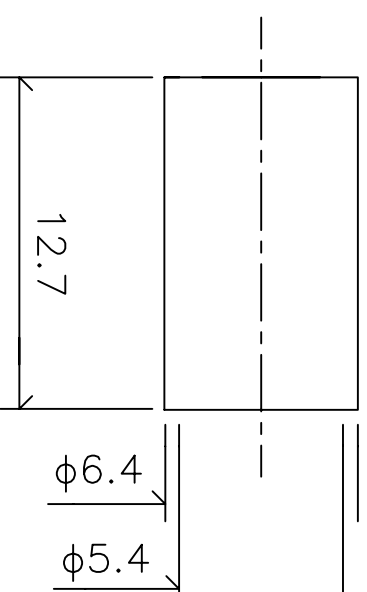
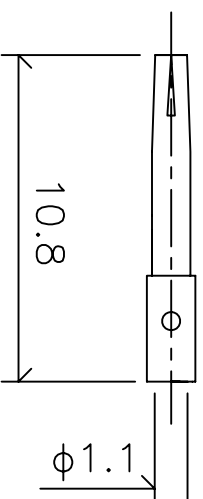
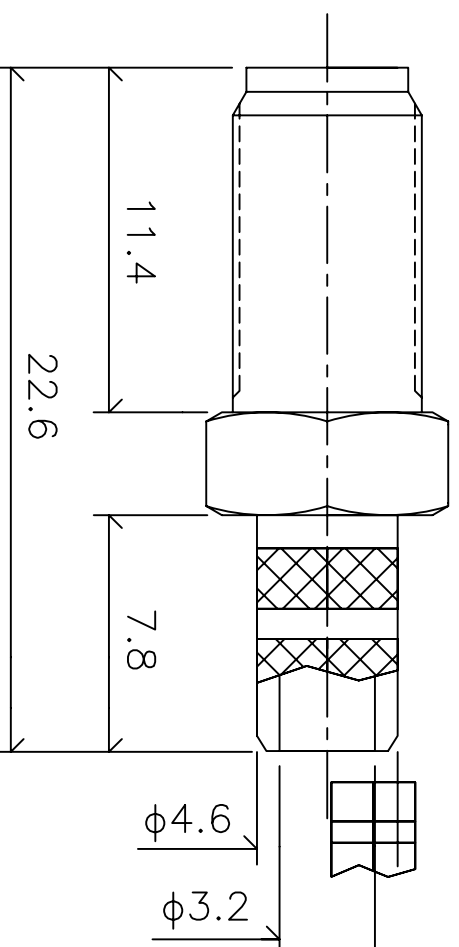

**Mechanical**

- ① Body: Brass Gold Finish 5 μ Inch
  - ② Center contact: Be Copper, Gold Finish 30 μ Inch
  - ③ Insulator: Teflon
- Brass Material: Cd < 75ppm, Pb < 40,000ppm  
 RoHS Regulation: Comply  
 Durability: 500cycles

**Electrical**

Impedance: 50 Ω  
 Frequency: DC-12.4GHz  
 V.S.W.R: 1.19Max at 2.0GHz  
 Insulation Resistance: 5000MΩ Minimum  
 Contact Resistance:  
 Center Contact: 4m Ω  
 Outer Contact: 3m Ω  
 Insulator Withstanding Voltage: 750VRMS

△	-	-		
△	-	-		
△	-	-		
△	-	-		
△	-	-		

未記入公差		尺度	単位	TAKITEK	
長さ公差: ±	0.08		mm	タキテック株式会社	
直径公差: ±	0.03				
				製品名	SMA Jack for RG58
					(φ5.0mm) Flex Cable
				部品名	T124 318 000
				製図	
				設計	
				照査	