

SMA117-15.4 T124498000TU
 品名: SMA フランジマウント プラグ 2穴 全長: 15.4mm、端子: 1.27mm タブ端子

SMA117-15.4

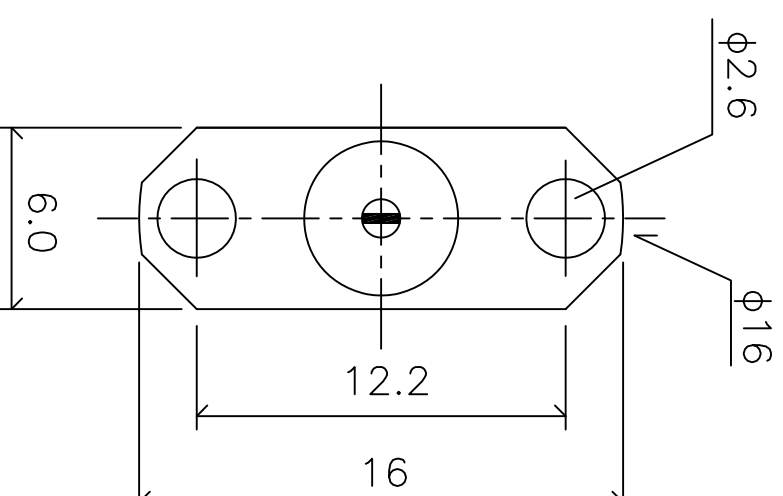
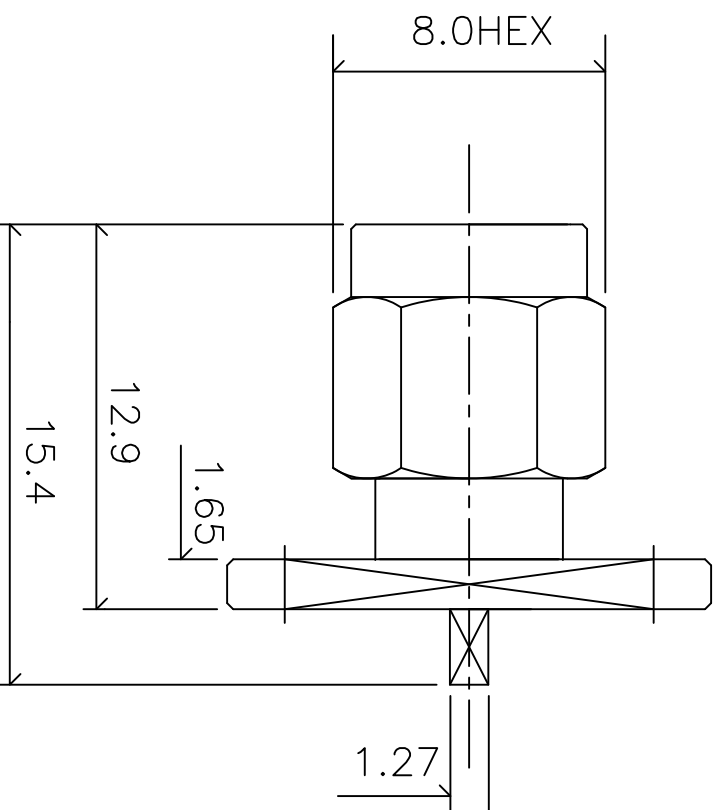

Electrical

Impedance: 50 Ω
 Frequency: DC-12.4GHz
 V.S.W.R: 1.19Max at 2.0GHz
 Insulation Resistance: 5000MΩ Minimum
 Contact Resistance:
 Center Cocontact: 4mΩ
 Outer Contact: 3mΩ
 Insulator Withstanding Voltage: 750VRMS

Mechanical

- ① Body: Brass Gold Finish 5 μ Inch
 - ② Center contact: Brass, Gold Finish 30 μ Inch
 - ③ Insulator: Teflon
 - ④ Fellule: Brass Gold finish 5 μ Inch
- Brass Material: Cd < 75ppm, Pb < 40,000ppm
 RoHs Regulation: Comply
 Dulability: 500cycles

△	-	-		
△	-	-		
△	-	-		
△	-	-		
△	-	-		

未記入公差	尺度	単位	TAKITEK
長さ公差: ± 0.08		mm	タキテック株式会社
直径公差: ± 0.03		mm	
			製品名
			SMA 2Hole Frange Mount
			Plug
			部品名
			T124 498 000