

RSMA825A-174 T300124351TU

品名: RSMA バルクヘッドジャック  
G174 RG316 ケーブル(φ2.6mm)用

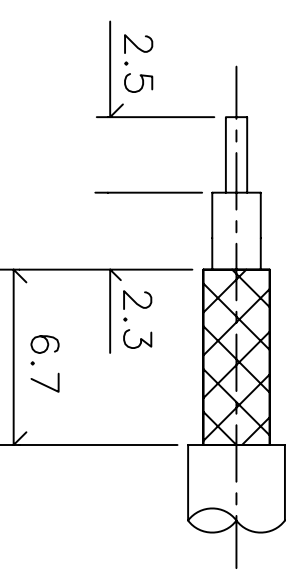
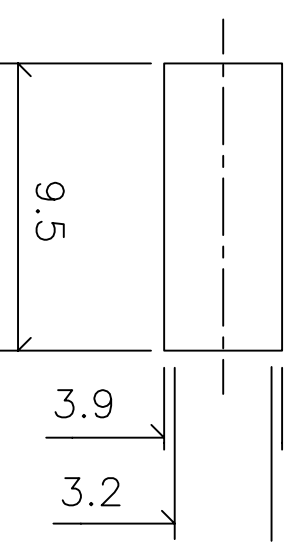
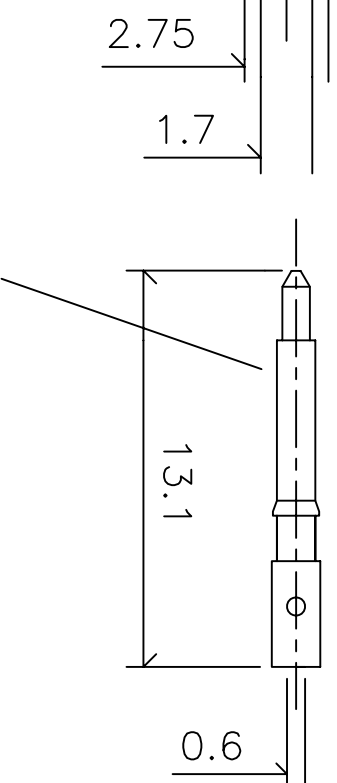
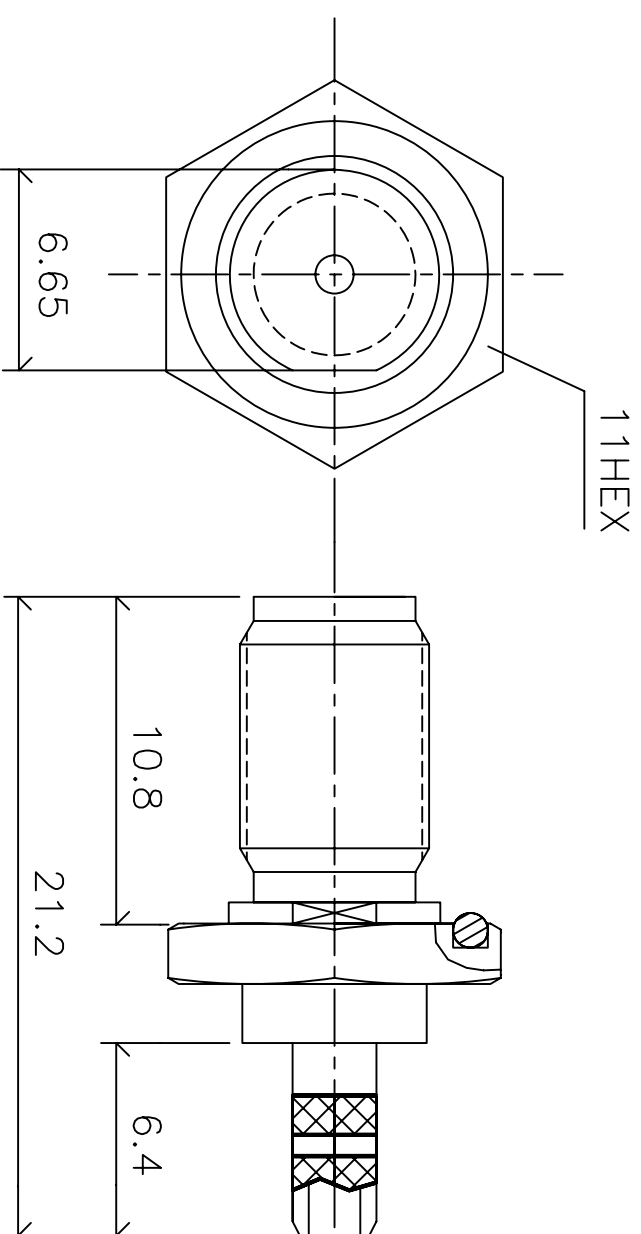
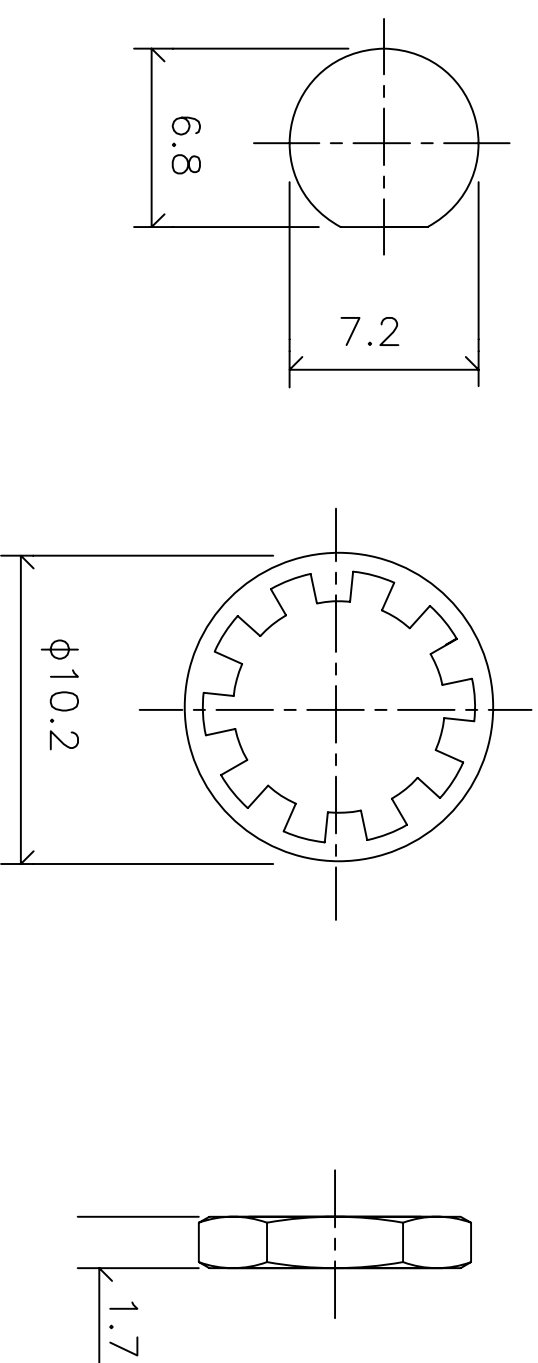

逆極性(ジャックのボデーにオスの中心胴体)  
リバーシラリゼーション

**Electrical**

Impedance: 50 Ω  
Frequency: DC-12.4GHz  
V.S.W.R: 1.19Max at 2.0GHz  
Insulation Resistance: 5000MΩ Minimum  
Contact Resistance:  
Center Coantact:: 4mΩ  
Outer Contact: 3mΩ  
Insulator Withstanding Voltage: 750VRMS

**Mechanical**

- ① Body: Brass Gold Finish 5 μ Inch
  - ② Center contact: Brass, Gold Finish 30 μ Inch
  - ③ Insulator: Teflon
  - ④ Fellule: Brass Gold finish 5 μ Inch
- Brass Material: Cd < 75ppm, Pb < 40,000ppm  
RoHs Regulation: Comply  
Dulability: 500cycles

△	-	-	
△	-	-	
△	-	-	
△	-	-	

未記入公差		尺度	単位	TAKITEK	
長さ公差: ±	0.08		mm	タキテック株式会社	
直径公差: ±	0.03				
製品名	RSMA bulkhead Jack for			部品名 T300 124 351	
	RG174 (φ2.6mm)				
製図	設計	照査			